

## BOND BEHAVIOR AT EXTERIOR BEAM COLUMN JOINT OF LOW STRENGTH CONCRETE UNDER CYCLIC LOADING

Mir Md. Saif Ali\*<sup>1</sup>, Md. Rakib Hasan<sup>2</sup>, Sadia Tahsin Quadir<sup>3</sup>, Mehedi Hasan Palash<sup>4</sup>, Raihan Ahmed Rifat<sup>5</sup>, A.F.M. Saiful Amin<sup>6</sup>

<sup>1</sup>Bangladesh University of Engineering and Technology, Bangladesh, e-mail: [mirsaiif469@gmail.com](mailto:mirsaiif469@gmail.com)

<sup>2</sup>Bangladesh University of Engineering and Technology, Bangladesh, e-mail: [rakibhasanmahin2000@gmail.com](mailto:rakibhasanmahin2000@gmail.com)

<sup>3</sup>Bangladesh University of Engineering and Technology, Bangladesh, e-mail: [sadia.tahsin.5537@gmail.com](mailto:sadia.tahsin.5537@gmail.com)

<sup>4</sup>Bangladesh University of Engineering and Technology, Bangladesh, e-mail: [mhpalash166@gmail.com](mailto:mhpalash166@gmail.com)

<sup>5</sup>Bangladesh University of Engineering and Technology, Bangladesh, e-mail: [rarone5t@gmail.com](mailto:rarone5t@gmail.com)

<sup>6</sup>Professor, Bangladesh University of Engineering and Technology, Bangladesh, e-mail: [samin@ce.buet.ac.bd](mailto:samin@ce.buet.ac.bd)

**\*Corresponding Author**

### ABSTRACT

Beam-Column joints are the critical locations in the reinforced concrete structures as they experience a massive amount of deformations during earthquake. In recent earthquakes in developing countries, severe damage was observed on reinforced concrete buildings. In this study an experimental campaign was carried on exterior beam-column joints constructed using less strength concrete and deficient beam rebar anchorage which represents the existing scenario in many buildings of developing countries those before the 1990s that do not comply with current seismic codes. This paper investigates the critical aspect of bond behavior between low strength concrete and reinforcement bars within exterior beam-column joints subjected to cyclic loading. Four 0.5-scale exterior beam-column joint specimens with varying strength levels and anchorage length were rigorously tested under cyclic loading conditions to assess their performance and behavior. The effects of concrete strength, bar diameter, and embedment length on the bond behavior as well as bond degradation and bond-slip behavior is analyzed. The joints exhibited the same failure mode, which involved shear failure of joints. Cyclic loading induces cumulative damage and deformation. Initially, elastic deformation occurs, followed by plastic deformation and eventual failure. The plastic damage distribution of the joint could be directly determined using a reinforcement strain analysis. The analytical predictions of yield moment and maximum joint moment in the positive and negative directions using the moment calculation equations were compared with the test results. The hysteresis results showed a clear picture that higher strength concrete and a larger development length exhibited stronger bond strength with reinforcement compared to low strength concrete. The findings emphasize the importance of specifying appropriate concrete strengths, development lengths, and bar diameters in design and ensuring proper construction practices to achieve optimal bond behavior and durability.

**Keywords:** Yield, Deformation, Embedment, Hysteresis, Pull out.

## 1. INTRODUCTION

Reinforced concrete (RC) structures are widely used globally, especially in developing countries, due to their strength, durability, and cost-effectiveness. Beam-column joints are crucial components responsible for load transfer between the beam and column, playing a pivotal role in maintaining structural integrity. Failure of these joints can lead to the collapse of the entire structure, with catastrophic consequences.

In many developing countries, buildings often have substandard beam-column joints due to outdated design codes or non-compliance with seismic standards. These poorly designed joints lack proper reinforcement, leading to increased risk of damage or collapse during earthquakes. Ensuring safety and reliability in concrete structures, especially in developing countries, is crucial. Low-strength concrete is commonly employed in structures with a limited design life or where high strength isn't necessary, like low-rise or temporary structures. However, the bond behavior of low-strength concrete in beam-column joints under cyclic loading is not well-explored. The significance of pull out phenomena in this context has not been thoroughly investigated, leaving a gap in understanding their impact on the behavior of beam-column joints.

Through experimental and analytical methods, it explores key parameters influencing bond behavior, such as concrete strength, reinforcement detailing, joint geometry, loading patterns, and pull out behavior. The study contributes to existing knowledge by observing failure patterns in low-strength concrete specimens and determining pull out force variations. The ultimate goal is to understand the factors influencing pull out strength in these conditions.

This research aims to understand the interaction between concrete and reinforcement bars under varying conditions, including different concrete strengths, reinforcement detailing, joint geometries, and loading patterns. The investigation employs experimental testing, specifically limited to exterior beam-column joints and the bond behavior of low-strength concrete. The study did not cover the behavior of high-strength concrete or other types of joints in concrete structures. Additionally, this research did not address the behavior of the entire structure, as the focus is on the beam-column joint's bond behavior. The experimental testing involves constructing concrete specimens with diverse properties and subjecting them to cyclic loading. The obtained results have been compared and validated to ensure accuracy, shedding light on critical parameters like concrete strength affecting bond behavior.

## 2. EXPERIMENTAL SETUP AND TESTING PROCEDURE

### 2.1 Materials and Specimens

Four specimens were prepared with a deformed bar and a straight anchorage of beam longitudinal bars for evaluating bond behavior at the exterior beam column joint of low-strength concrete under cyclic loading. The concrete was mixed on-site, and each specimen required three batches. Only second specimen had a concrete strength of 25 MPa, while the other three had a concrete strength of 10 MPa. Reinforcing bars with a yield strength of 450 MPa were used in all specimens. First two specimens had  $16 d_b$  embedment length, second and third had  $13 d_b$  and  $10 d_b$  respectively. The specimens were built with low-strength concrete with a maximum aggregate size of 20 mm, which was made by combining cement, sand, and brick chips in a volumetric ratio of 1:2:4 with a water-to-cement ratio of 0.6.

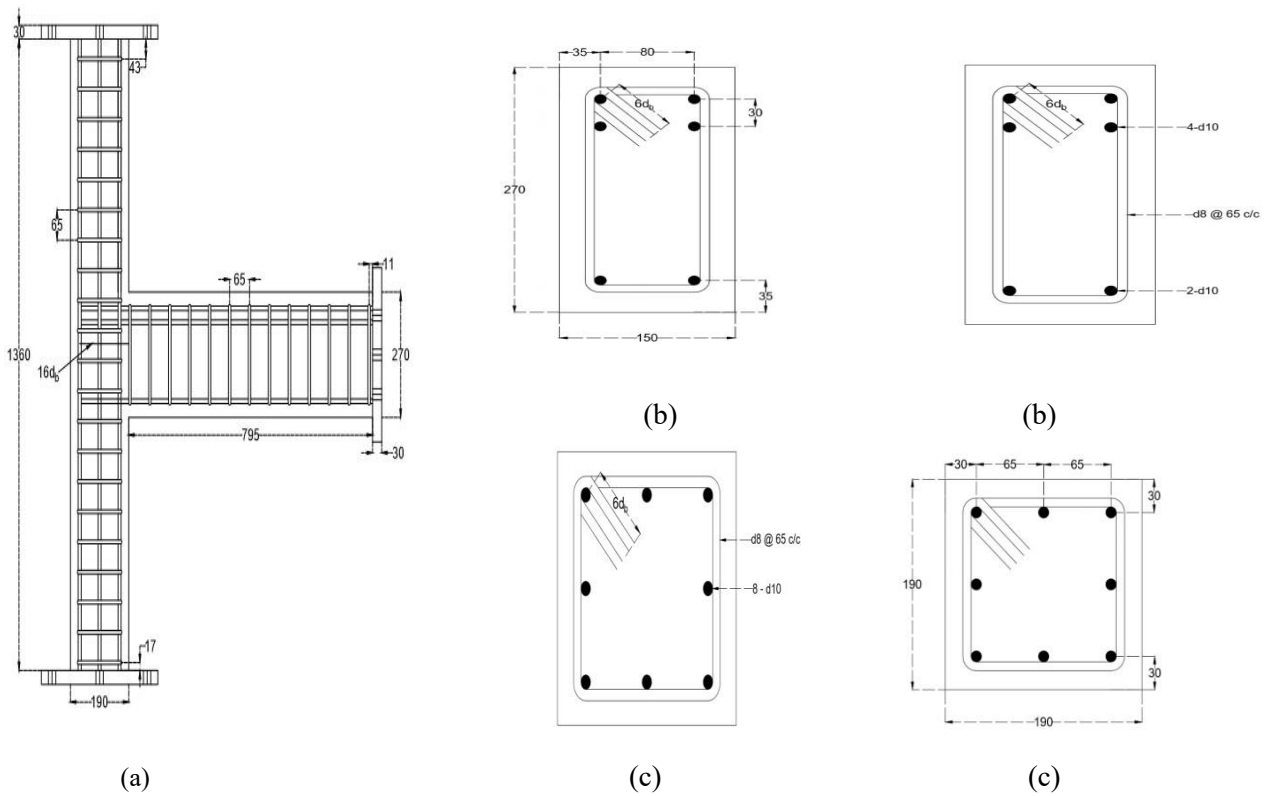

Figure 2.1: Detailing of (a) Specimen, (b) Beam, (c) Column

## 2.2 Loading Configuration

The maximum vertical load capacity 360 kN for the setup. The vertical jacks applied a constant axial load with an axial load ratio of 0.10. So, we applied 36 kN total in both jacks. Horizontal load is applied to simulate the seismic load by HORIZONTAL jack to obtain the drift ratio. The drift ratios for the cycles were as follows: 0.25%, -0.25%, 0.5%, -0.5%, 0.75%, -0.75%, 1%, -1%, 1.25%, 1.25%, 1.5%, -1.5%, 1.75%, -1.75%, 2%, -2%, 2.5%, -2.5%.....up to ultimate failure.

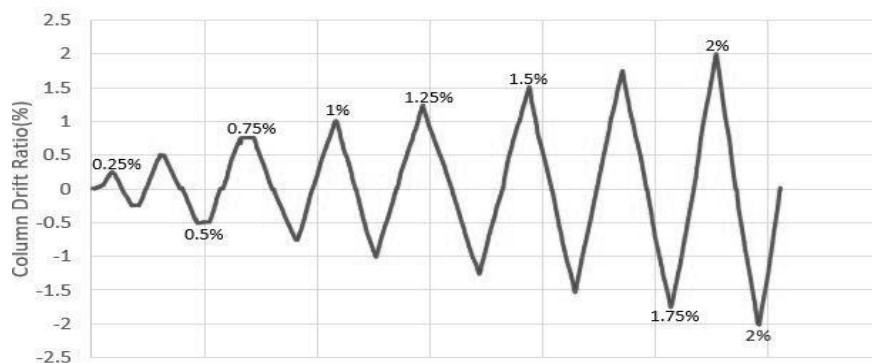

Figure 2.2: Loading Configuration

### 2.2.1 Test Procedure and Sequence

In assessing bond behavior at external beam-column joints, specimens are prepared to mimic real structures, equipped with sensors for data collection. Fixed to a rig, cyclic loading simulates seismic conditions. Collected data, including displacements and strains, informs analysis. Interpretation of results guides evaluation, identifying vulnerabilities and aiding in seismic resilience enhancement. Proper execution ensures dependable data for effective structural design and retrofitting.

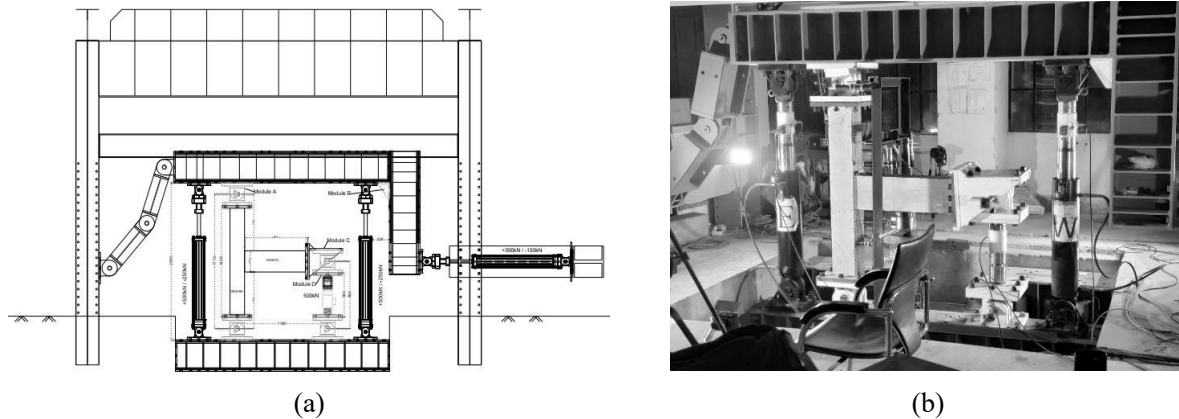

Figure 2.3: Testing setup: (a) AutoCAD drawing, (b) laboratory setup

## 2.3 Load Application and Monitoring

### 2.3.1 Load and Displacement Measurement

Load and displacement measurements, facilitated by specialized sensors like load cells and displacement transducers, are vital for comprehensive assessment of beam-column joint behavior under cyclic loading. Real-time load data aids in understanding load distributions and potential overloading scenarios, informing structural capacity evaluation. Displacement measurements, utilizing devices like LVDTs and strain gauges, quantify joint deformation characteristics. The simultaneous recording of joint moment and strain data enables detailed analyses, including the study of energy dissipation and elastic-plastic behavior. These precise measurements contribute essential insights into the joint's performance and long-term safety.

### 2.3.2 Data Acquisition and Processing

Data acquisition and processing were integral in scrutinizing the behavior of beam-column joints under lateral cyclic loading. Instrumentation, featuring sensors like load cells and LVDTs, precisely measured loads, deformations, and displacements. These sensors continuously recorded data during cyclic loading, digitally captured and stored by a comprehensive data acquisition system. Specimens 1 to 4 yielded substantial strain gauge responses, enabling accurate analysis of their behavior.

The TDS 7130v2 software facilitated meticulous data presentation with multiple graphs and value monitors. Extracting data to Excel files allowed for in-depth analysis, unveiling essential parameters like stress-time curves. Joint moment data, coupled with drift ratio values, elucidated the joint's response

7<sup>th</sup> International Conference on Civil Engineering for Sustainable Development (ICCESD 2024), Bangladesh to lateral displacement, depicted through hysteresis loops showcasing energy dissipation. Extracted data also aided in identifying failure modes, offering insights into the limitations and potential weaknesses of the beam-column joint under lateral cyclic loading. This thorough analysis contributes to a comprehensive understanding of structural performance and informs potential enhancements.

## 2.4 Quality Control Measures

For quality control in assessing bond behavior at external beam-column joints with low-strength concrete under cyclic loads, ensure a well-designed concrete mix, verify reinforcing bar properties, and adhere to specimen standards. Follow recognized testing standards, develop a detailed test plan, and document procedures for consistency. Install strain gauges and displacement transducers, use accurate loading methods, and employ data acquisition systems for precise measurements. Refer to regional design codes and standards for tailored quality control, guaranteeing thorough evaluation and reliable outcomes in the assessment of bond behavior in low-strength concrete beam-column joints subjected to cyclic loading.

## 3. STRENGTH ESTIMATION

Recent publication of the most recent Bangladesh National Building Code (BNBC) 2020 provides tight guidelines for seismic details of RC buildings. Numerous existing structures do not adhere to the code's criteria. The provisions related to the concrete structures in the BNBC 2015 based on the ACI 318-11.

### 3.1 Code Requirements on Anchorage of Beam Rebar into Exterior Joints

The anchorage of beam rebar into exterior joints should be designed to satisfy the requirement of development length for rebar in tension. Equations (1) to (4) show the required development length for deformed bar without hooks in tension ( $l_d$ ) based on the BNBC 2020 code, which is similar to that of the ACI-17 code.

$$l_{d1} = \frac{f_y \psi_t \psi_e}{2.1 \lambda \sqrt{f'_c}} d_b \text{ for } d_b < 19 \text{ mm} \quad (1)$$

$$l_{d2} = \left( \frac{f_y}{1.1 \lambda \sqrt{f'_c}} \frac{\psi_t \psi_e \psi_s}{\frac{c_b + k_{tr}}{d_b}} \right) d_b \quad (2)$$

$$l_{d3} = 300 \text{ mm} \quad (3)$$

$$l_d = \max(l_{d1}, l_{d2}, l_{d3}) \quad (4)$$

where  $f_y$  is the yield stress of longitudinal reinforcement;  $\psi_t$  is the rebar location factor; that accounts for the position of rebar in freshly placed concrete (where horizontal reinforcement is placed such that more than 300 mm height of fresh concrete is cast below the development length, use  $\psi_t = 1.3$ ; for other reinforcement, use  $\psi_t = 1.0$ ); in this study,  $\psi_t = 1.0$  is used for all beam longitudinal bars;  $\psi_e = 1.0$  for uncoated reinforcement;  $\lambda = 1.0$  for normal-weight concrete;  $f'_c$  is the compressive strength of concrete;  $d_b$  is the diameter of the longitudinal reinforcement;  $\psi_s = 0.8$  for bar diameter  $< 19$  mm;  $c_b$  is the minimum value between the distance of the bar center to the nearest concrete surface and one-half of the center to center spacing of the bar;  $K_{tr} = 0$  as a design simplification even if transverse reinforcement is present; and  $\left( \frac{c_b + k_{tr}}{d_b} \right)$  is not taken greater than 2.5

### 3.2 Strength Estimation of Specimen Equations

According to the Japanese standard (JBDPA -The Japan Building Disaster Prevention Association) The ultimate strength of the frame,

$$M_u = \min \left[ ({}_n M_{cu1} + {}_n M_{cu2}), {}_n M_{bu}, M_{ju} \right] \quad (5)$$

The flexural strength of the column,

$$M_{cu} = 0.8\alpha_t \sigma_y D_c + 0.5ND_c \left(1 - \frac{N}{bD_c F_c}\right) \text{ (for } 0 \leq N \leq 0.4b D_c F_c \text{)} \quad (6)$$

The flexural strength of the beam,  $M_{bu} = 0.9\alpha_t \sigma_y d$  (7)

The ultimate shear strength,  $V_{ju} = \kappa \emptyset F_j b_j D_j$  (8)

$$b_j = b_b + b_{a1} + b_{a2} \quad (9)$$

Joint Moment, 
$$M_{ju} = \frac{V_{ju}}{\frac{L - D_c}{L_b} - \frac{1}{L_c}} \quad (10)$$

where  ${}_n M_{cu1} / {}_n M_{cu2}$  is the nodal moment at the joint of upper/lower column (N.mm);  ${}_n M_{bu}$  is the nodal moment at the joint of beam (N.mm);  $M_{ju}$  is the moment capacity of the joint (N.mm);  $\alpha_t$  is the gross area of tensile longitudinal rebar ( $\text{mm}^2$ );  $\sigma_y = f_y$  ( $\text{N/mm}^2$ );  $F_c = f_c'$  ( $\text{N/mm}^2$ );  $d$  is the Effective depth of the beam;  $D_c$  is the Full depth of column (mm);  $N$  is the column axial force (N);  $b$  is the column width (mm);  $\kappa$  is the Joint shape factor (0.7);  $\emptyset = 0.85$ ;  $F_j$  is the nominal value for calculating the joint shear strength ( $\text{N/mm}^2$ ) =  $0.8F_c^{0.7}$

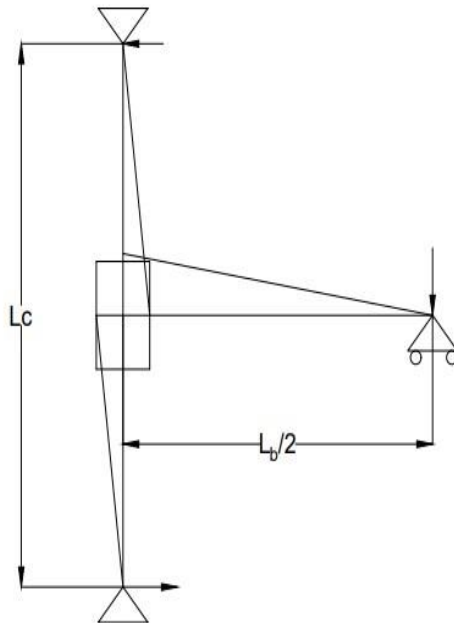

$${}_n M_{bu} = M_{bu} \frac{L_{b/2} - D_{c/2}}{L_{b/2}}$$

$${}_n M_{cu1} = M_{cu1} \frac{L_{c/2} - D_{b/2}}{L_{c/2}}$$

$${}_n M_{cu2} = M_{cu2} \frac{L_{c/2} - D_{b/2}}{L_{c/2}}$$

Fig. 3.1: Seismic moment diagram

#### 4. EXPERIMENTAL RESULTS AND DISCUSSION

Under cyclic loading, an exterior beam-column joint experiences repeated loading cycles, accumulating damage. Initially elastic, the joint shifts to plastic deformation, culminating in failure. Plotting joint moment against drift ratio forms a characteristic butterfly curve. This behavior is crucial in designing

joints, influencing strength, stiffness, and durability. Engineers, understanding this, optimize designs to prevent premature failure. The joint's response under cyclic loading guides the design

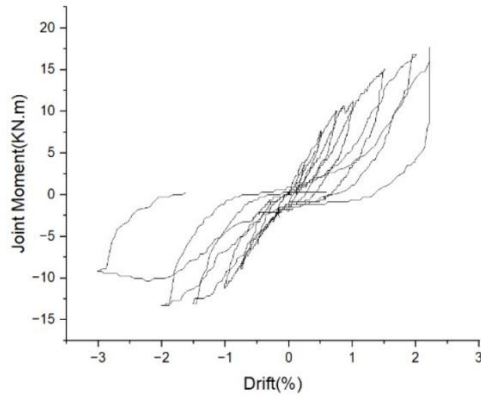

Fig. 4.1: Joint moment vs drift ratio curve for SP-1

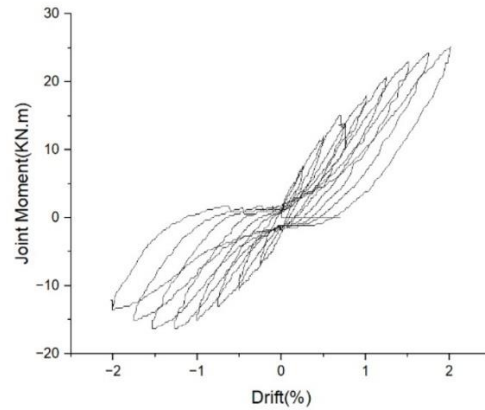

Fig. 4.2: Joint moment vs drift ratio curve for SP-2

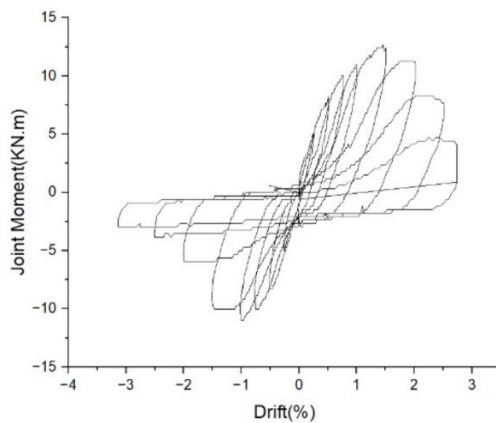

Fig. 4.3: Joint moment vs drift ratio curve for SP-3

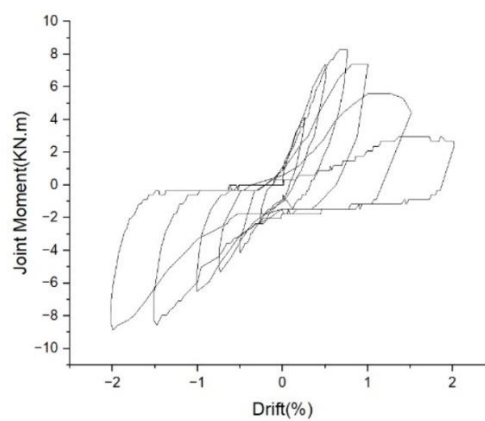

Fig.4.4: Joint moment vs drift ratio curve for SP-4

#### 4.1 Comparison of Test Results

This analysis focuses on bond behavior variations between concrete strengths. The load-slip responses offer insights into exterior joint bonds. The experimental results reveal joint behavior differences based on concrete strength. The 10 MPa specimens displayed maximum moments of 17.74 kN-m, 12.71 kN-

7<sup>th</sup> International Conference on Civil Engineering for Sustainable Development (ICCESD 2024), Bangladesh m, and 8.28 kN-m, while the 25 MPa specimen peaked at 25.13 kN-m. For 10 MPa specimens, curves exhibit gradual slip increase until peak resistance, followed by softening. Conversely, the 25 MPa specimen, with higher strength, is expected to display a stiffer response.

Table 4.1: Equivalent Joint moment at the ultimate strength of the specimen

Specimen	Loading direction	At column flexural strength ${}_nM_{cu1}+{}_nM_{cu2}$ (kN.m)	At beam flexural strength ${}_nM_{bu}$ (kN.m)	At joint shear strength $M_{ju}$ (kN.m)	Expected ultimate strength $M_u$ (kN.m)
SP-1	Positive	69.6	41.84	14.8	14.48
SP-2	Positive	69.6	41.84	27.58	27.58
SP-3	Positive	69.6	41.84	14.8	14.48
SP-4	Positive	69.6	41.84	14.8	14.48

Peak resistance is higher, achieved at a larger slip, and the load decline with slip is less pronounced due to enhanced bond strength.

#### 4.2 Failure Mode

In the beam column joint different modes of failure can occur. Shear failure is a common mode of failure in beam-column joints. It occurs when the shear forces exceed the capacity of the joint to resist them. This failure mode is characterized by diagonal cracking and shear failure planes, resulting in a loss of load-carrying capacity. Flexural failure occurs when the moments applied to the joint exceed its flexural capacity. This failure mode is characterized by the development of flexural cracks, loss of stiffness, and reduction in load-carrying capacity. Splitting failure occurs due to the concentrated bond stress at the interface between the reinforcing bars and the surrounding concrete. It typically occurs in the vicinity of the beam-column joint and is characterized by radial cracks propagating from the rebar ends or the joint interface. Anchorage failure refers to the failure of the reinforcement anchorage within the joint region. It occurs when the development length of the reinforcing bars is insufficient or when the bond strength between the bars and the surrounding concrete is inadequate.

In some cases, multiple failure modes can occur simultaneously or sequentially, leading to combined failure modes. For example, shear and flexural failures can occur concurrently, affecting the overall behavior and performance of the joint.



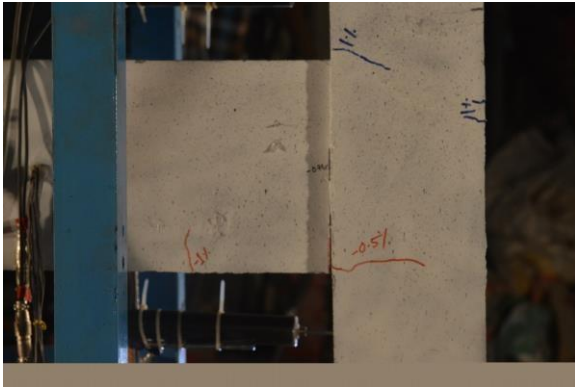

Fig. 4.5: Failure Mode of Specimen-1

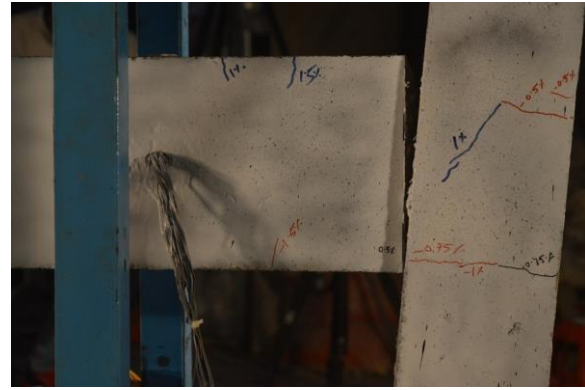

Fig. 4.6: Failure Mode of Specimen-2



Fig. 4.7: Failure Mode of Specimen-3

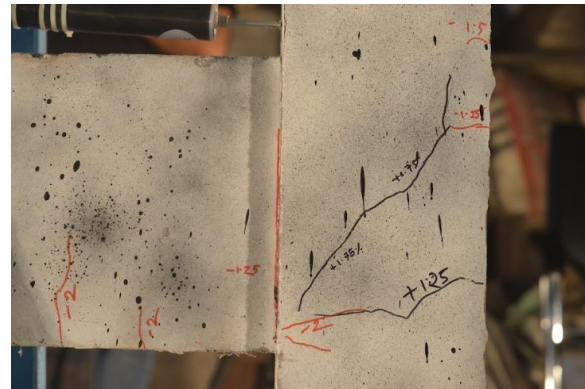

Fig. 4.8: Failure Mode of Specimen-4

In Specimen-1, it is observed that at -0.5% drift ratio, horizontal crack has started to propagate. When the drift ratio increases to 0.75%, there is a visible crack in the beam column interface and this crack widens with increasing drift ratio. At -1% drift ratio, we can see some diagonal crack at beam column joint. In -1% drift ratio, crack occurs in beam also. So, specimen-1 has failed in Shear failure. In Specime-2, it is observed that at both +0.5% and -0.5% drift ratio, horizontal crack has started to propagate at beam column joint. There is also a crack at beam column interface at 0.5%. There are more horizontal cracks observed at 0.75% drift ratio. When the drift ratio increases to 1%, we can see some diagonal at beam column joint. At 1.5% drift ratio we see some vertical crack in the beam. Moreover, it is sighted that cyclic loading has done serious damage to the structure splitting the beam from column. So, specimen-1 falls under Shear failure. In Specime-3, it is observed that at 0.25% drift ratio, horizontal crack and diagonal crack have started to occur. When the drift ratio increases to 0.5%, there is a visible crack in the beam column interface and this crack widens with increasing drift ratio. There is also crack in column at this drift ratio. At 1% drift ratio, the specimen fails at beam column interface with loud cracking sound. So, specimen-3 has failed in Shear failure. In Specime-4, it is observed that at both +0.75% drift ratio, diagonal crack has started to propagate at beam column joint. There is a crack at beam column interface at -1.25%. There are also some diagonal and horizontal cracks observed at -1.25% drift ratio. When the drift ratio increases to -2%, we can see some vertical crack at beam. So, specimen-4 falls under Shear failure.

## 5. CONCLUSIONS

This thesis comprehensively evaluates the influence of concrete strength and development length on bond behavior in the exterior beam-column joint of low-strength concrete structures under cyclic loading. Experiments showed notable bond behavior differences between 25 MPa and 10 MPa concrete

7<sup>th</sup> International Conference on Civil Engineering for Sustainable Development (ICCESD 2024), Bangladesh strengths. The 25 MPa specimen had a stiffer response, higher bond strength, and uniform stress distribution, while the 10 MPa specimens were softer, with lower bond strength and non-uniform stress distribution. This highlights the vital role of higher concrete strength in effective load transfer and robust bond integrity. Examining the bond stress-slip relationship showed that the 25 MPa specimen had a robust bond with higher peak bond stress at larger slip values. In contrast, the 10 MPa specimens exhibited lower peak bond stress and softer behavior, indicating challenges in achieving strong bond integrity in low strength concrete. Durability considerations emphasize concrete strength's vital role in addressing environmental challenges. The 25 MPa specimen exhibits enhanced resistance to moisture, carbonation, and chloride penetration, contributing to long-term bond integrity and overall structural performance.

In summary, this thesis enhances the understanding of bond behavior in low-strength concrete structures, providing valuable insights for engineers, researchers, and practitioners involved in their design and assessment. The study emphasizes the critical role of development length and development length. Balancing the impact of bar diameter on bond strength with construction considerations, designers must carefully manage bar diameter and spacing to ensure proper compaction without causing congestion issues. The findings underscore the pivotal importance of proper construction practices, including compaction, curing, and reinforcement placement, in ensuring optimal bond behavior. Inadequate practices can diminish bond strength and durability, posing a risk to the structural integrity of low-strength concrete structures, under cyclic loading conditions.

## ACKNOWLEDGEMENTS

We would like to express our heartfelt gratitude to Saumik Mallik and Richa Dutta Rakhee, research assistants (RA) for their assistance and knowledge sharing throughout the thesis. They have helped us to conduct experiments, and providing insightful discussions. We feel incredibly fortunate to have had the privilege of working under their supervision. It is indeed a great privilege for us having the unique opportunity to work on such an important topic.

## REFERENCES

Wardi, S., Sanada, Y., Saha, N., & Takahashi, S. (2020). Improving integrity of RC beam-column joints with deficient beam rebar anchorage. *Earthquake Engineering & Structural Dynamics*, 49(3), 234-260..

Japan Building Disaster Prevention Association. (2005). English version: Standard for seismic evaluation of existing reinforced concrete buildings. *Japan Building Disaster Prevention Association: Tokyo, Japan.*

‘Bangladesh-National-Building-Code-2020.pdf’ (no date). Available at: <https://mccibd.org/wp-content/uploads/2021/09/Bangladesh-National-Building-Code-2020.pdf> (Accessed: 12 January 2024).

ACI 369.1-17 Standard Requirements for Seismic Evaluation and Retrofit of Existing Concrete Buildings (ACI 369.1-17) and Commentary an ACI Standard Reported by Committee 369 Wassim M. Ghannoum, Chair (3.5—Development and splices of reinforcement, p. 25).